

7512-82

Nondestructive testing. Welded joints.
Radiography method

MKC 25.160.40

01.01.84

1 400 , , - ,

.

1.

1.1. , , , ,

1.2. , , , , , , ,

1.3. : . .

- -

;

- () , , .1;

- , ,

1.1—1.3. (, . **1**).

1

(24034)	()
40 .40 » 100 » 100 » 150 » » 150 » 200 » » 200	0,1 0,2 0,3 0,4 0,5
1.4. - — (, . 1).	0,2, - -

. 2 7512-82

2.

2.1.

2.2.

2.3.

20426.

2.4.

2.5.

2.6.

2.7.

2.8.

2.9.

15843.

1.

2.

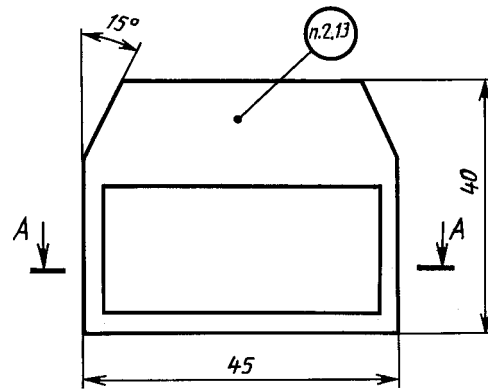

A-A

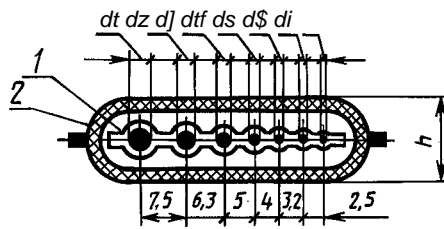

1— ; 2—

. 1

2.10. .1
 .2. — (20±0,5) :
 0,2 ... ±0,01
 . 0,2 » 1,6 ... ±0,03
 » 1,6 » 4,0 ... ±0,04

2

	4		d_3	d_4	d_5	d_6	d_7	h
1	0,2	0,16	0,125	0,10	0,08	0,063	0,05	1,2
2	0,4	0,32	0,25	0,20	0,16	0,125	0,10	1,4
3	1,25	1,00	0,80	0,63	0,50	0,40	0,32	2,2
4	4,0	3,20	2,50	2,00	1,60	1,25	1,00	5,0

— ±0,5

(, . 1). .2 .3
 2.11.

liUULn^:

.2

3

													h		L			
	h	h_2	h		h	h									1.			
i	0,60	0,5	0,40	0,3	0,20	0,10	-0,05	0,1	2,5	+0,30; +0,150	0,5	+0,2; +0,1	10	-0,360	2	-0,100	30	-0,52
2	1,75	1,5	1,25	1,0	0,75	0,50	-0,10	0,2	4,0	+0,40	1,5	+0,3	12	-0,430	4	-0,120	45	-0,62
3	—	—	3,00	2,5	2,00	1,50	-0,25	0,3	6,0	+0,40	3,0	+0,3	14	-0,430	6	-0,120	60	-0,74
	4,00	3,5	—	—	—	—	-0,30											

2.12.
. 4.

. 3

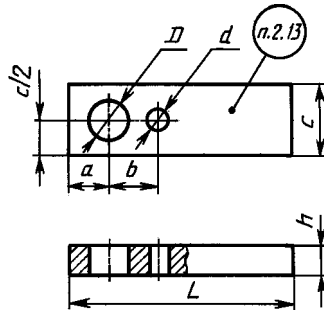

. 3

4

	<i>h</i>		<i>D</i>		<i>d</i>								<i>L</i>	
	-	.	-	.	-	.	-	.	-	.	-	.	-	.
1	0,1	-0,01	0,2	+0,01	0,1	+0,01	5	+0,15	5	±0,15	10	-0,36	25	-0,52
2	0,2	-0,025	0,4	+0,025	0,2	+0,025								
3	0,3		0,6		0,3									
4	0,4		0,8		0,4									
5	0,5		1,0		0,5									
6	0,60	-0,06	1,2	+0,06	0,60	+0,06	6	7	±0,18	12	-0,43	35	-0,62	
7	0,75		1,5		0,75									
8	1,00		2,0		1,00									
9	1,25		2,5		1,25									
10	1,5	-0,1	3,0	+0,10	1,5	+0,1	7	±0,18	9	14		45		
11	2,0		4,0	+0,12	2,0									
12	2,5		5,0	+0,12	2,5									

2.13.
15843

3.

, () —
: — 1,
— 2, — 3, — 4, — 5.

2.14.

3.

h.

38,5_{-0,62}, 3—53_{-0,74}

1 27_{-0,52}, 2 —

2.15.

3.

3.1.

3.2.

()

3.1, 3.2. (, . 1).

3.3.

3.4.

3.5.

3.6.

3.7.

5

3.8.

5

3.9.

100

5

3.10.

3.11. (, . 1).

3.12.

3.13.

.5.7.

3.14.

()

()

(, . 1).

4.

4.1.

.4 5.

4.2.

.6.

4.2 .

(. 5 , , , ,).

- . 5 (

) — 100%-

2

- . 5 — 100 %-

, ;

. 5

- ; .5 —

2 ;

- .5 , —

10 ;

.5

(, . 1).

4.3.

. 5

100 ; .5 , —

50 .

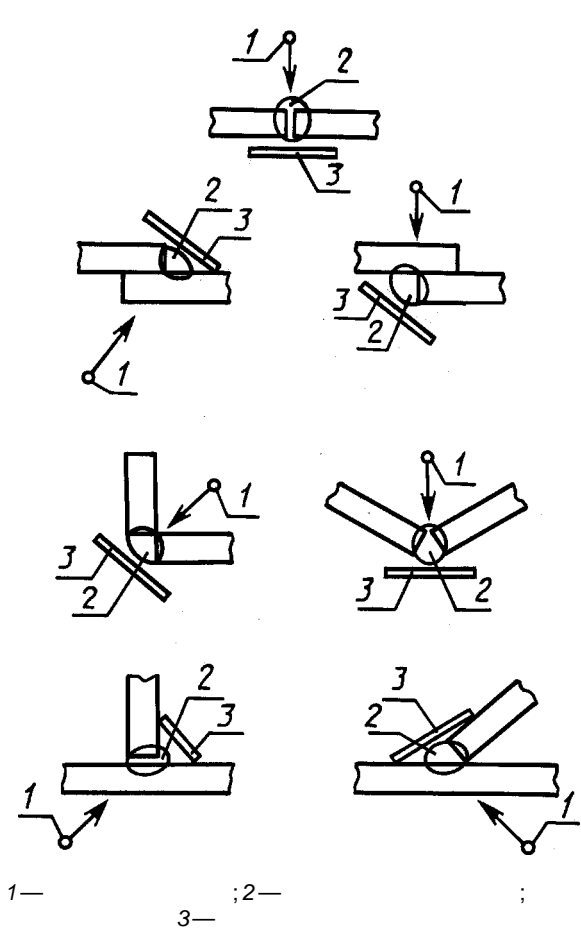

. 4

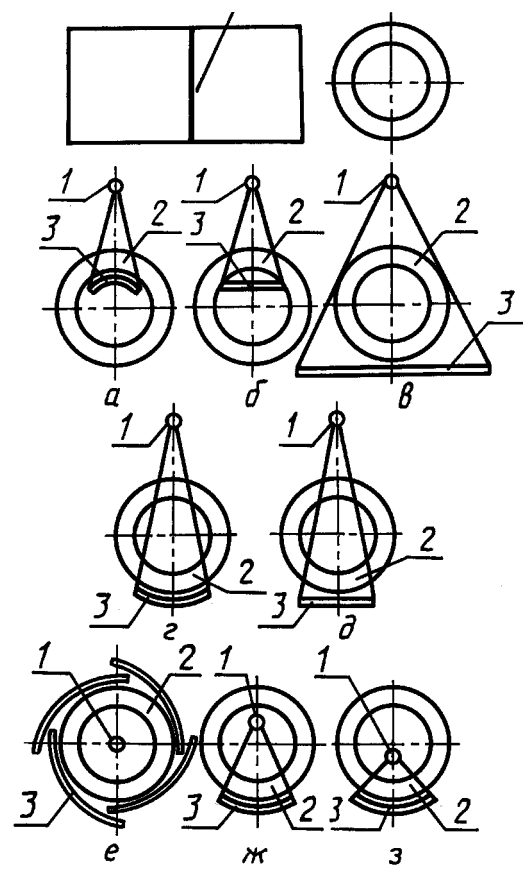

. 5

4.4.

. 5 , , , ,

1— ; 2— ; 3—

4.5.

45°.

. 5 ,

. 6

45°.

4.3—4.5. (1).
4.6. (1).
4.7.

. 4—6,

4.8.

(. .),

4.9.

150 ;

4.7—4.9. (45° , . 1).

5.

5.1.

() (. 5)

2 1 — 2 ;

1,25; (,)

45°;

1,0.

5.2.

. 4—6,

4. , . 1).

5.1, 5.2. (

5.3. d D . 5 ()

0,8,

$\frac{Kd}{2(D-d)}$

5.4 ,) . 5.3 (

5.5.

. 5 , . 5.3,

5.6.

5.7 .100 — 20 . 100 0,2 ,
 , :
 - 5 — 5 ;
 20 — — .5 20 ;
 - — .20 ;

6.

6.1.

1(¹⁺² / 2, —

(6.2. , . 1).
 - ; , , :
 - ; , ,
 - ; , ,
 - 1,5; ,
 -

6.3.

1,0.

(

),

.6.

()			
	1	2	3
5	0,10	0,10	0,20
.5 9	0,20	0,20	0,30
» 9 » 12 »	0,20	0,30	0,40
» 12 » 20 »	0,30	0,40	0,50
» 20 » 30 »	0,40	0,50	0,60
» 30 » 40 »	0,50	0,60	0,75
» 40 » 50 »	0,60	0,75	1,00
» 50 » 70 »	0,75	1,00	1,25
» 70 » 100 »	1,00	1,25	1,50
» 100 » 140 »	1,25	1,50	2,00
» 140 » 200 »	1,50	2,00	2,50
» 200 » 300 »	2,00	2,50	—
» 300 » 400 »	2,50	—	—

0,30; 0,60; 0,75

1,50

0,32; 0,63; 0,80 1,60 .

(, . 1).

(, ,) -

6.4

(:)

$$= 100,$$

6.5. $\frac{S}{-}$, ; , . -

- , : , -

- , ;

6.6.

(, , , ,).

6.7.

1,2; 1,5; 2,0; 2,5; 3,0

0,2; 0,3; 0,4; 0,5; 0,6; 0,8; 1,0;

3,0 .

6.8.

$$\wedge > 10'$$

$$\frac{f+S}{f+S+H'}$$

/—

6.9. $\frac{s}{66-68}$ (, . 1).

0,1 , .1,5 — 1,5

6.10. 1 .

6.11.

5.

6.

7.

7.1.

7.2.

7.3.

7.4.

«

» -72/80 2120—80,
18 1980 „ « — — 7 » -76 141—76,
1976 „ «
» 1171—74,
7 1974 . 23764.

7.5.

« »
« 12 1969 . »

7.6.

« 1139—73, 27 1973 . -73
7.7.

8.

8.1.

5 .

8.2.

8.3.

()

8.4. ()

8.5.

()

8.6.

.),

. 8. (, . 1).

100		0,02
100 300		0,05-0,09
300		0,09
¹⁷⁰		0,09
⁷⁵ Se; ¹⁹² I		0,09-0,20
¹³⁷ Cs		0,20-0,30
"		0,30-0,50
	1 15	0,50-1,00

—
—
—

;

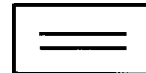
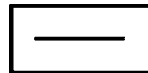

;

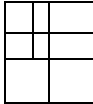
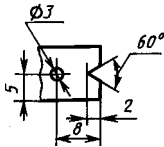
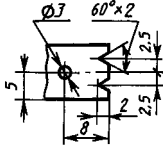
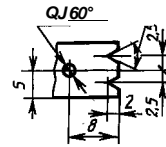
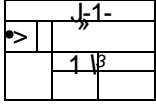
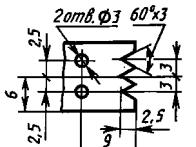
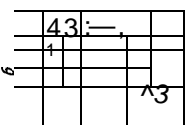
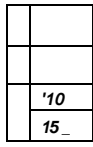
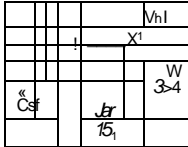
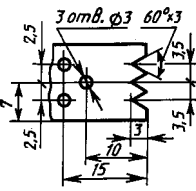
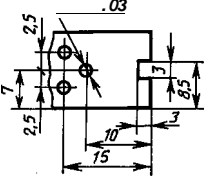

	200		1,0
	¹⁷⁰ Tm; ⁷⁵ Se		1,0
	200		1,0 2,0
	¹⁹² I; ¹³⁷ Cs; "		1,0 2,0
15	1		.2,0

		15843
	1,2 3,4	5 6
	1 2 3	5 6 7
	1-5 6-9 10-12	5 6 7

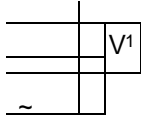
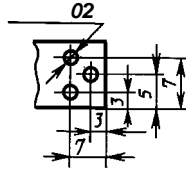
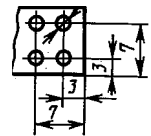
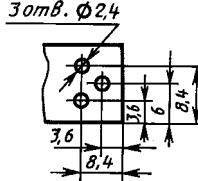
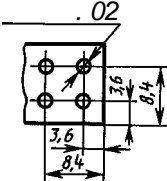
				
$2 \sqrt{\quad} .03$ £	$2 \quad .03$ *	$2 \quad ,03 60/2$ S		$2 \quad 6.03$ 
$\quad ,03$ 	$\quad <.03$ 15	8.03 		$\quad .03$ 

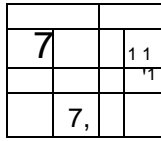
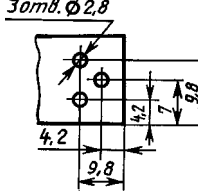
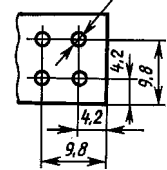
0 t	$2 \quad .02$ 	02 	$* \quad .02$ 
02	$2 \quad .02,4$ if	$30mm \cdot \phi 2,4$ 	$\quad .02$ 
$02,8$ 	$2 \quad .02,8$ 	$30mm \cdot \phi 2,8$ 	

1. ()

1

--	--

.4 6
.5
.5
.5
.5

Cs
0,7 (l-m) D
CD
0,5[1,5 (1-)-1] D
0,5[(1,4-)-1] D

$$= -\sqrt{1 - \dots} > 2 = 4 < 2;$$

s —
D —
—
—
—

> 1, / . 5 , (. 1,5 (1 -) > 1 (1,4 -) >

2. . 4 6

0,8/ (,) . 5 , , , .2.

2

.5

$$180^\circ$$

$$\arcsin 0,7 - \arcsin \frac{0,7}{2} + 1$$

$$2$$

$$180^\circ$$

$$\arcsin pm + \arcsin \frac{pm}{2n + 1}$$

.5

.5, d

$$m = \frac{d}{D} \cdot n \cdot \frac{f}{D}; p \quad 1-0,2 \quad 2,6 \frac{42}{m}$$

d —
4. .56 / /

$$1 < d; f > 0,5C\{l-m < l^{\wedge} \neq\} D,$$

$$= \frac{b(2 + 1)}{\sqrt{(2 + 1 - m^2) - 2^2 + 2^2}}$$

$$q < \sqrt{1 - 0,2} \quad \frac{\sqrt{2}}{2,6} \quad / \quad / \quad -$$

$$N$$

$$* = \frac{\arcsin \frac{qm}{2} - \arcsin \frac{qm}{2 + 1}}{\dots}$$

5. . 5 () / (),

$$l > 0,5 (1 -) D.$$

$$\frac{0,25^2 (1 - ^2)}{2(+ 1)}$$

N

$$N > \frac{180^\circ}{\arcsin m + \arcsin \frac{m}{2n - m}}$$

6. . 5

$$\frac{180^\circ}{N} \pm 3^\circ$$

. 5 , , , , — 7

7. -

. 4 6. 2 , , , , 4. (, . 1).

1.

2345678

		D		Da Db Dc
				Ab Ac
			1(111)	Ba Bb
				Ca Cb Cc
			—	—
		Fa		
		Fb		
		Fc		
		Fd		

2.

(

100

100)

3.

:

-

—

;

-

,

—

(

);

-

,

,

,

—

4.

,

(

).

5.

)

(

6.

(

100

7.

»

«

»,

—

«

».

8.

,

.1,

5.(

,

. 1).

1. 5 3 , 30 15
- 2 . 100 20 .
:5 ; 30 5 3; HI15 2; £20.
2. (10 , -
0,5) (8 ,
2 1). 100 18 .
3. :2 10 0,5; 8 2 1; £18. 15 40 .
4. :2 15; 40. 4 20 .
100 12 .
:5 4; £12; 20.

- 1. 20.12.82 4923
- 2. 7512-75
- 3. -

12.2.007.0-75	7.3
15843-79	2.1, 2.13, 3
20426-82	2.3
23764-79	7.4
24034-80	1.3
25347-82	3

- 4. , _____ (3—93 5-6—93)

- 5. (2004 .) 1, 1988 . (6—88)

..
..
..
..
.. 02354 14.07.2000. 117 . 2400. .532. 20.05.2004. . .2,32. - . .2,80.
,107076 , „14.
<http://www.standards.ru> e-mail: info@standards.ru
— .“ „,105062 , .6.
080102